

Daily Maintenance Sheet for VJ-1638UH

Daily maintenance

The content of this documents are based on the specification of the firmware Ver.1.04 or later.

When to maintain:

- After operation (Be sure to perform the following maintenance)
- When the media strikes the print head

Required Items:

- (a) Plastic gloves (Supplied accessories or Commercial item)
- (b) Rubber gloves (Supplied accessories or Commercial item)
- (c) Protective goggles (Supplied accessories)
- (d) Paper towel (Supplied accessories) or Polyester knit wiper (Optional accessories)
- (e) Dropper (Supplied accessories)
- (f) Dedicated maintenance cleaner (Optional accessories)
- (g) Plastic cup (Supplied accessories)
- (h) Cleaning stick (Supplied accessories or Optional accessories)
- (i) Stick scraper (Supplied accessories) or Scraper (Supplied accessories)

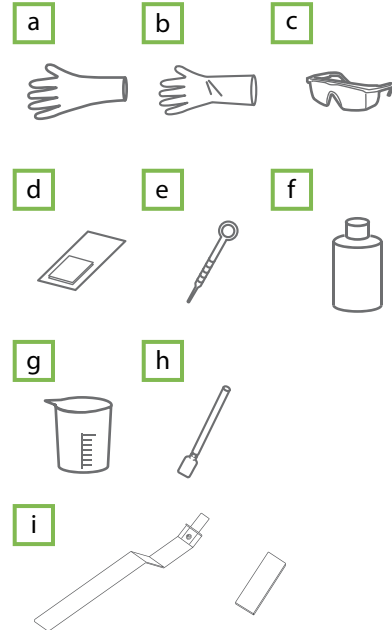

- ※Use a paper towel supplied with the printer or optional Polyester knit wiper. DO NOT use a tissue.
Lints or flakes on tissue may cause damage to the print head.
- ※DO NOT use non-dedicated maintenance cleaner.

Preparation:

- Wear the rubber gloves (white) over the plastic gloves (pink).
- Wear protective goggles.

CAUTION

- ❗ Skin or eye contact with UV curable ink may cause skin inflammation or allergic reaction.
For this operation, be sure to wear the supplied gloves (or solvent resistant gloves) and goggles to prevent ink from contacting with your eyes or skin.

Important!

Before performing maintenance, make sure to read "How to handle UV inkjet printer / its supplies" (supplied with the printer).

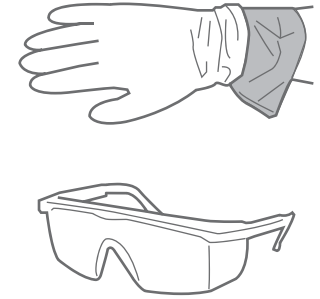

- Press the [MENU] key on the operation panel.
- When [Menu 1: Sleep Mode >] appears on the operation panel, press the [>] key.
- Press the [+]/[-] key on the operation panel to select [Sleep Mode 3: Start].
- Press the [Enter] key on the operation panel.
- When [Start Sleep Mode?] appears on the operation panel, press the [Enter] key.
- When [Daily Maint.: Start] appears on the operation panel, press the [Enter] key.
- When [Daily Maint.: End] appears on the operation panel, you can start the maintenance with following steps.

※Make sure to complete this maintenance within 10 minutes while the printer is in Daily maintenance state.

Open the maintenance cover on the left of the printer and remove it.

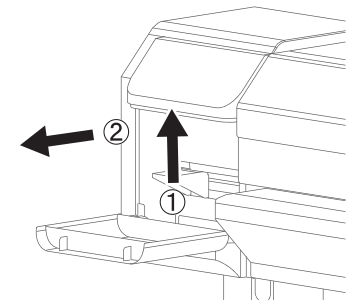

1. Cleaning of UV Lamp

- 1** Check for any ink or dust on the UV lamps (x2).
- If no ink or dust is found on the UV lamp, skip this step and move on to "2. Moistening the surface of print head nozzles".

- 2** If any ink or dust is found, using a paper towel, remove ink and dust from the UV lamp.
- *If ink deposits cannot be removed with the paper towel, use the scraper supplied with the printer.
 - Press the scraper on the ink deposits with a slight angle and scrape off the ink deposits.
 - Use the paper towel to clean the ink scraped from the lamp.
 - *The illustration below shows an example when cleaning the left UV lamp.

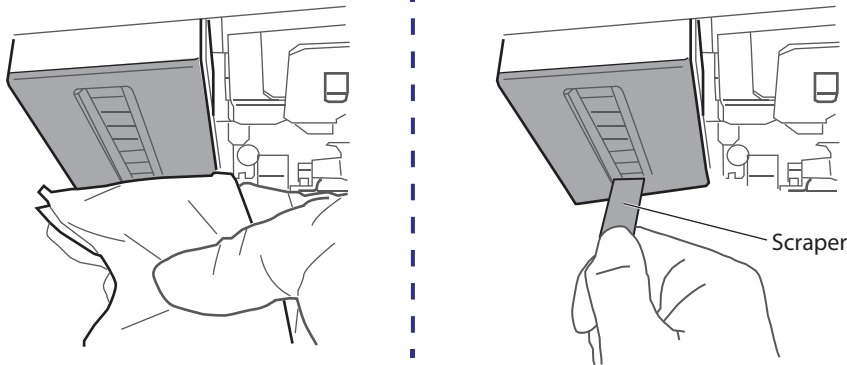

- *When cleaning the right side UV lamp, use the stick scraper supplied with the printer.
- Open the front cover. Then, press the stick scraper on the UV lamp surface and scrape ink deposits off.
- Use the paper towel to clean the ink scraped from the lamp.

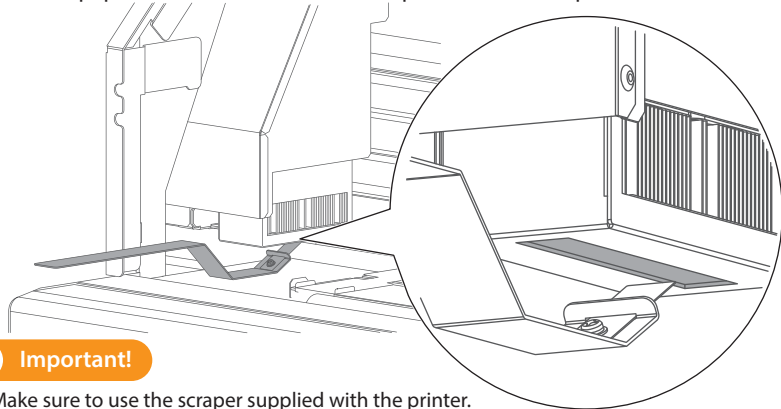

Important!

- Make sure to use the scraper supplied with the printer.
- Never use the corner of the scraper. It can damage the UV lamp.
- When using the scraper, do not apply too much pressure to the lamp. It can damage the UV lamp.

Next moisten the surface of print head nozzles.

2. Moistening the surface of print head nozzles

Important!

During cleaning, please note the followings:

- Always follow this steps to perform daily maintenance.
When moistening the surface of nozzles, do not use the cleaning stick already used to clean the print head circumference, cleaning wiper or cap circumference. Doing so may result in damage to the print head.
- Always use a new cleaning stick and dampen it with dedicated maintenance cleaner.
DO NOT use non-dedicated maintenance cleaner. It may cause nozzle clogging.
- Do not touch the tip of a cleaning stick with fingers. If sebum is adhered, it can cause damage to the print head.
- Do not reuse a cleaning stick. Dusts can adhere causing damage to the print head.

- 1**
- Put a cleaning stick in the plastic cup.
 - Use the dropper to dampen the swab of cleaning stick with dedicated maintenance cleaner.
(Amount used: 0.5 ml)

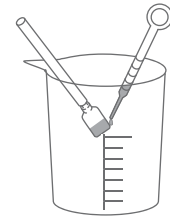

- 2**
- Look the bottom of the carriage. Using the cleaning stick dampened with the maintenance cleaner, moisten the surface of the print head nozzles.
 - Lightly touch with the cleaning stick to moisten the nozzle surface.
 - Repeat it a couple of times to moisten the entire nozzle surface.
 - ※DO NOT rub into the nozzle surface.
It can cause damage to the print head.
 - ※If the entire nozzle surface has been moistened, you can stop it.

Next clean the print head circumference.

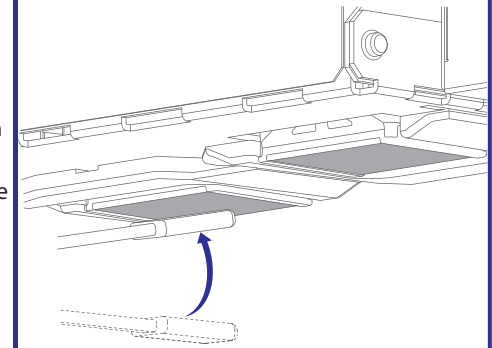

3. Cleaning of print head circumference

1 Look the bottom of the carriage.
Check if dusts and ink deposit are adhered.

- Print head circumference (silver metal part)
- Print head guide part (black plastic part)

※If maintenance cleaner is splashed onto the printer,
use a paper towel to wipe it off.

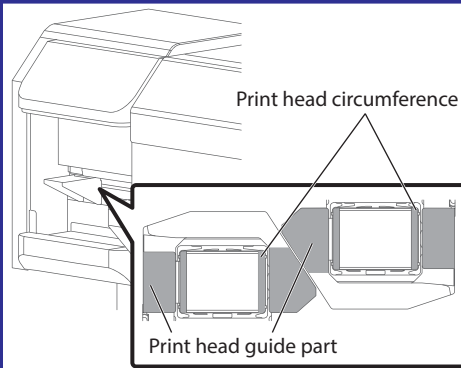

2 If dusts or ink deposit are adhered, clean with a cleaning stick.

■ Cleaning required

■ DO NOT touch the surface of a print head (the yellow portions in the illustration below)

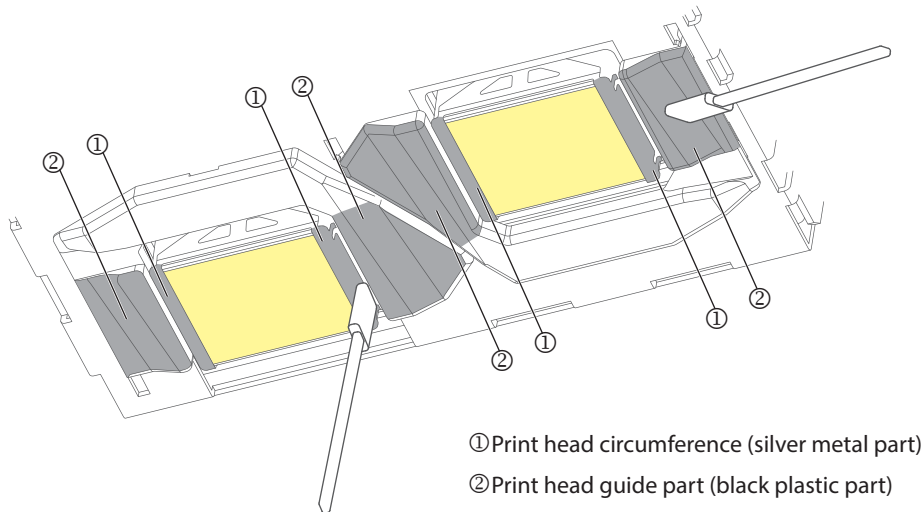

① Print head circumference (silver metal part)

② Print head guide part (black plastic part)

3 Attach the maintenance cover on the left of the printer and close it.

Next clean the cleaning wiper and the cap circumference.

4. Cleaning of cleaning wiper and the circumference of the cap

1 Open the maintenance cover on the right of the printer and remove it.

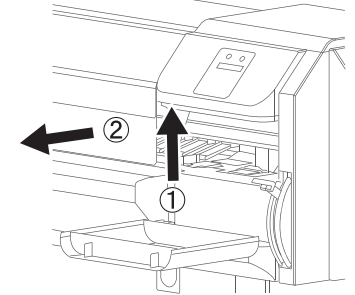

2 Use the cleaning stick to clean the left side surface of the cleaning wiper (a black rubber part).

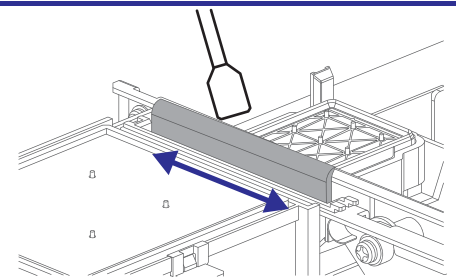

3 Clean the right side surface of the cleaning wiper.

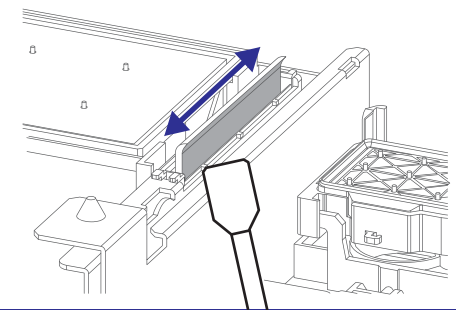

4 Use the cleaning stick to remove the ink and dust on the circumference of the cap.

■ Cleaning required

■ DO NOT touch the absorber
(the yellow portions in the illustration right)

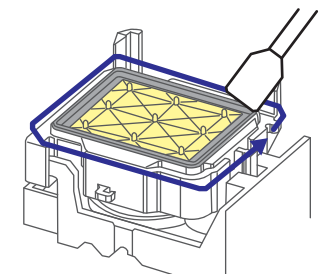

5 Attach the maintenance cover on the right of the printer and close it.

Next finish the daily maintenance.

5. Finishing daily maintenance

1 Press the [Enter] key on the operation panel.

- The printer automatically performs the Short cleaning.
- When the Short cleaning is complete, the printer automatically enters to sleep mode.

Daily Maint. : End

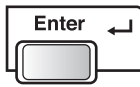

2 • Dispose of the used cleaning stick.

• Use a paper towel to wipe the maintenance cleaner off the dropper.

• Dispose of the maintenance cleaner in the plastic cup and dry the cup well using the paper towel.

• Now the daily maintenance is complete.

Important!

- Do not reuse a cleaning stick.
Dusts can adhere causing damage to the print head.
- Check that the lid of the maintenance cleaner is shut properly and store it.

Maintenance before leaving printer in sleep mode for a long time



<Preparation before the maintenance>

- ▶ **Make sure that there is enough ink in ink cartridges.**
 Operation manual "Ink Status menu", "Replacing ink cartridge"
- ▶ **Empty the waste fluid tank.**
 Operation manual "Disposal the waste fluids"
- ▶ **Perform "Daily maintenance" (refer to [this sheet](#))**.

<Weekly maintenance>

To leave the printer in sleep mode for one week or longer, when one week has passed, perform the following:

- ▶ **Check the ink level.**
Replace the relevant ink cartridge if "Ink Low" is displayed.
- ▶ **Agitate the ink in the ink cartridge.**



Note

For purchasing the maintenance items, contact your local Mutoh dealer or nearest Mutoh sales office.

Name	Part Number	Minimum q'ty per order
Dedicated Maintenance cleaner	VJ-ULVA1-ML500	1
Polyester knit wiper	PJ-POLYNITW	300
Clean stick	RH2 Clean stick	100